

# Big Boat Car Couplers

Often found on curved track, couplers join two cars to form high-load assemblies.

Use high-load 580 and 752 couplers for single-point attachments. Use 1799 control block with 580 or 1770 couplers. Use single, double or triple Black Magic® AirBlocks® with the 752 coupler.



Cars not included

Part No.	Description	Length		Weight		Maximum working load		Breaking load		Fits
		in	mm	oz	g	lb	kg	lb	kg	
580	Coupler	7 <sup>1</sup> / <sub>4</sub>	184	21	595	6000	2722	12000	5443	3163
584	Mainsheet carrier	10	254	44	1247	6000	2722	12000	5443	3163
752	Coupler	10 <sup>3</sup> / <sub>4</sub>	273	28	794	9000	4082	18000	8165	3165
1770	Flat plate coupler*	4 <sup>3</sup> / <sub>8</sub>	111	3	84	3600	1630	8400	3810	3160/3163/3164

\*Custom flat plate coupler & modified 3165 & 3166 car assemblies available upon request

# Track Risers & Dodger Blocks

## Track Risers

Use 1849 risers for mid-boom travelers that must clear companionway hatches. Risers fit most cabintops and articulate for use with either straight or curved track. Sold in pairs.

## Dodger Blocks

These blocks route control lines to the deck from bridge-mounted travelers and pass under the dodger to cam cleats mounted within reach of the crew.

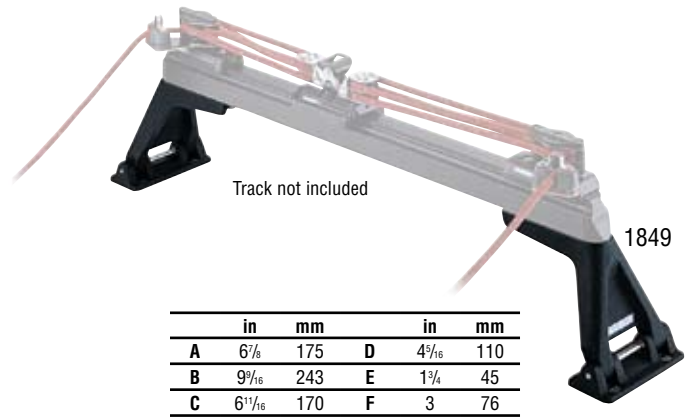

Part No.	Description	Fits	Weight	
			oz	g
1849	Track riser (pair)	1618/3156	131.2	3720
1985	6:1 Dodger block conversion kit (pair)	3185 Traveler control blocks	8	227