

**Technical Information** .....3  
**Introduction** .....4  
**Installation** .....5  
**Hydraulic Connections**  
    6.1 Hoses and Fittings.....6  
    6.3 Connections ..... 7-8  
    6.4 Connecting Hoses/Case Drain Circuit.....8  
**Electrical Connections**  
    7.1 Wire Size/Length Chart.....9  
    7.2 Electric Schematics ..... 10-17  
    7.3 Checking Electrical Controls..... 18  
**Starting**  
    8.1 Air Bleeding Procedure..... 19  
    8.2 Pressure Check ..... 19  
**Maintenance** ..... 19  
**Troubleshooting** .....20  
**Limited Warranty** .....20  
**Reference** ..... 21-23

**Important Warnings**

**Improper use of the machinery may cause serious damage to people and objects**

- Hydraulic oil may cause skin irritation.
- Hydraulic oil may damage paint and some surfaces.
- During cabling a short circuit may occur with risk of fire.
- Use only hydraulic oil Exxon Nuto H46 or equivalent.
- Never run the hydro pack without oil as this can seriously damage pump.
- Maximum pressure valve must be left as set by Harken otherwise power pack may not work properly.
- Make sure hose bends follow the minimum radius recommended in “Hoses and Fittings” Page 6.
- Before connecting make sure insides of hoses are clean and free of dirt that can damage valves.
- Harken hydraulic winches and furlers must have drainage hoses installed.
- Do not run system with low power batteries! Low voltage increases the ampere/hour consumed causing overheating of electric cables and motor.

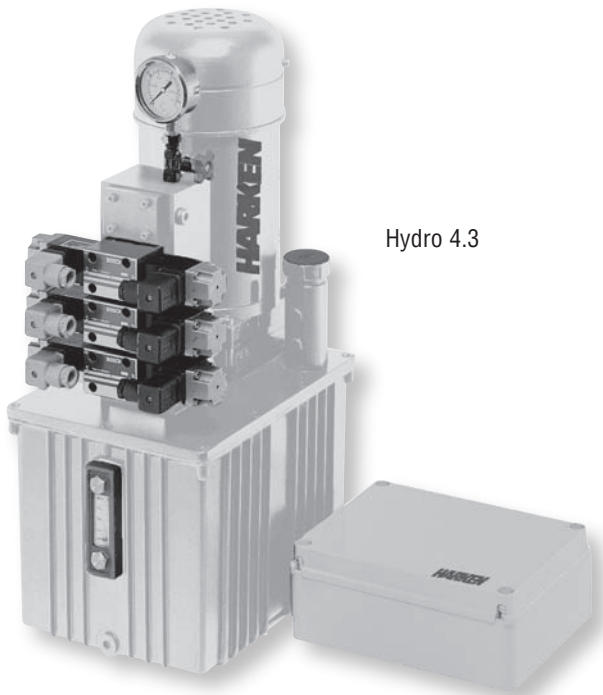

Hydro 4.3



Hydro 8



BRS104/P

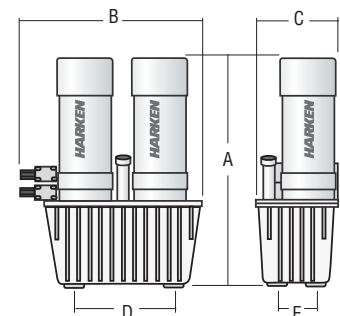
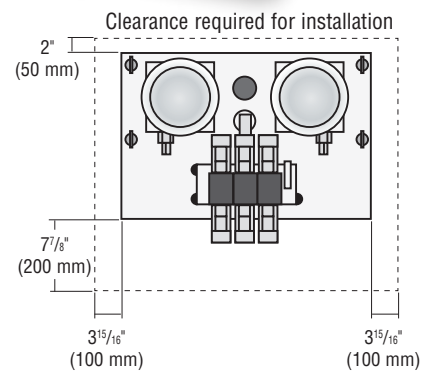

- All standard units use 3000-watt 24-volt electric motors, but the Hydro 4 can be ordered with a 12-volt motor.
- Units do not have quick-release hose couplings.
- Quick-release hose couplings are available as an option.
- All hydraulic power units are supplied with an electric control box.
- Electric push-buttons are available as an option. Two BRS102/P switches are suggested for each winch.

## Control Box

For power unit	Height		Width		Depth	
	in	mm	in	mm	in	mm
Hydro 4/Hydro 6/Hydro 8	5 <sup>1</sup> / <sub>8</sub>	130	15 <sup>9</sup> / <sub>16</sub>	395	12 <sup>13</sup> / <sub>32</sub>	315

## Deck Switches

Part No.	Description	Ø		Height		Weight		
		in	mm	in	mm	oz	g	
BRS102/P	Remote switch w/guard	2 <sup>11</sup> / <sub>16</sub>	68	1 <sup>3</sup> / <sub>16</sub>	21	4.5	128	2/winch
BRS104/P	Remote switch w/guard	3	76	¾	19	3.4	95	2/winch

Model	Hydraulic Functions*	Electric Motors
4.3	3	1
4.6	6	1
6.6	6	2
6.9	9	2
8.9	9	2
8.12	12	2

Every hydraulic winch or furling unit counts as a function

## Power Unit Dimensions

Part No.	A		B		C		D		E	
	in	mm	in	mm	in	mm	in	mm	in	mm
Hydro 4	25	635	16 <sup>17</sup> / <sub>32</sub>	420	9 <sup>7</sup> / <sub>16</sub>	240	9 <sup>13</sup> / <sub>16</sub>	250	6 <sup>1</sup> / <sub>16</sub>	170
Hydro 6	27 <sup>9</sup> / <sub>16</sub>	700	23 <sup>9</sup> / <sub>16</sub>	600	16 <sup>17</sup> / <sub>32</sub>	420	12 <sup>19</sup> / <sub>16</sub>	326	6 <sup>15</sup> / <sub>16</sub>	176
Hydro 8	29 <sup>15</sup> / <sub>16</sub>	760	31 <sup>1</sup> / <sub>2</sub>	800	18 <sup>11</sup> / <sub>16</sub>	475	15 <sup>9</sup> / <sub>16</sub>	395	10 <sup>13</sup> / <sub>16</sub>	275

Dimensions subject to change

Distance battery to power unit	Minimum wire size*				
	Hydro 4		Hydro 6, 8		
ft	m	gauge	mm <sup>2</sup>	gauge	mm <sup>2</sup>
0 - 15	0 - 5	3	25	00	70
15 - 33	5 - 10	1	35	000	95
33 - 50	10 - 15	0	50	0000	125

## Hydraulic Power Units

Part No.	Number of functions	Motor	Max current drain* amps	Tank capacity l gal	Max operating pressure		Flow rate @ 100 bar 1430 PSI*		Weight lb kg	Use with winches	Fasteners in mm
					Bar	PSI	l/min	gal/min			
Hydro 4	6	1 x 3000 watts	160	10 2.6	140 2030	9 2.4	132.3 60	44 - 74	¾	10	
Hydro 6	9	2 x 3000 watts	2 x 160	25 6.6	140 2030	24 6.3	198.5 90	44 - 980	¾	10	
Hydro 8	12	2 x 3000 watts	2 x 160	50 13.2	140 2030	36 9.5	264.6 120	44 - 1150	¾	10	

\*Values are based on 24 volts and will differ when using a 12-volt system

The Hydraulic Power Unit is a dynamic oil system which enables large yachts to be sailed much more easily.

The system is composed of one hydraulic power unit and related electric control box. It can support up to 12 different functions: hydraulic winches, hydraulic furlers, hydraulic cylinders; if they match flow and pressure values.

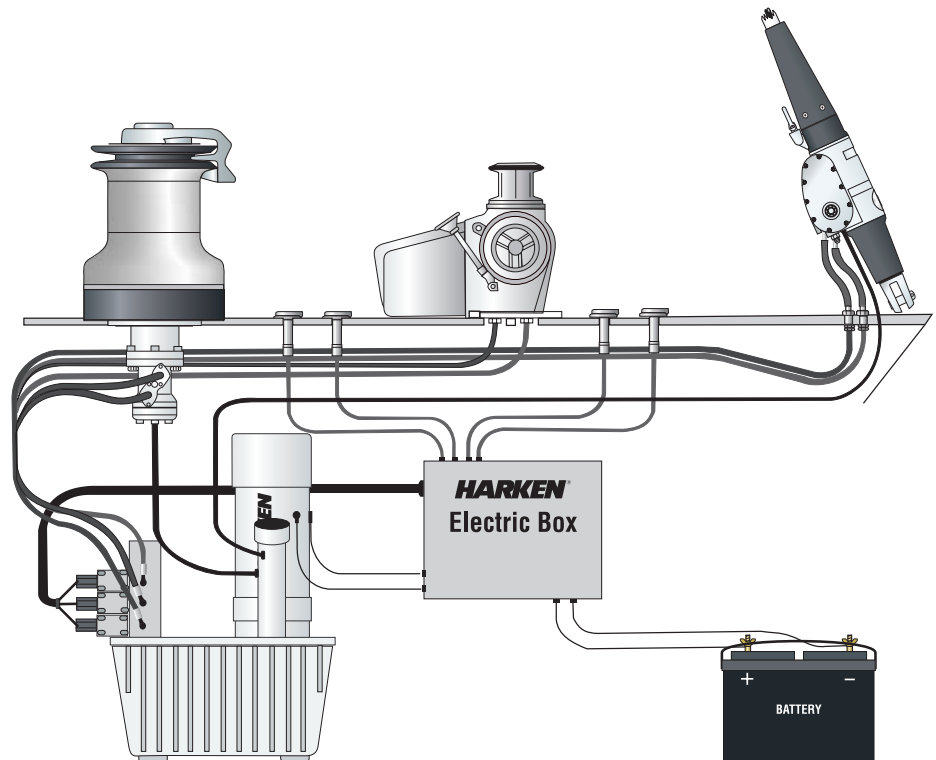

The Hydraulic Power Unit works when one of the electric push-buttons fitted on deck is depressed that is related to a function.

Every function, like a winch or furler usually has two push-button switches on deck; one for 1st gear and the other one for 2nd gear. In a 3-speed winch one push-button is used for 1st and 3rd gear while the other one is used for 2nd gear. In the case of our 1140 winch which features a hydraulic backwind, there are three push buttons on deck. Two of them are used for the two forward speeds as described above while the 3rd one is used to switch on the backwind.

### Directional Valve

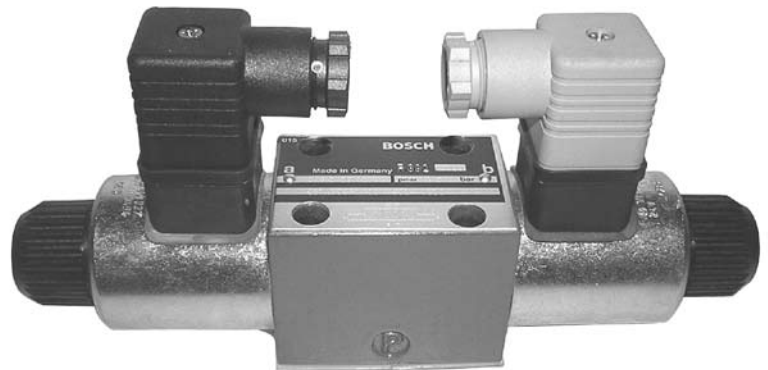

This starts the electric motor(s) linked to a pump fitted inside the oil reservoir. The oil is moved through a suction unit (via a filter) and is pumped to the valves. The valves are activated simultaneously with the motor(s), and thus let oil flow to the connected function.

Every time the oil feeds one hydraulic motor there is a two-way linking system featuring two hydraulic hoses. When a winch is run in 1st gear one of the hoses is the hydraulic motor inlet and the other one is the hydraulic motor outlet. In 2nd gear the hydraulic motor will reverse its rotation because the inlet will become the outlet, while the outlet will become the inlet.

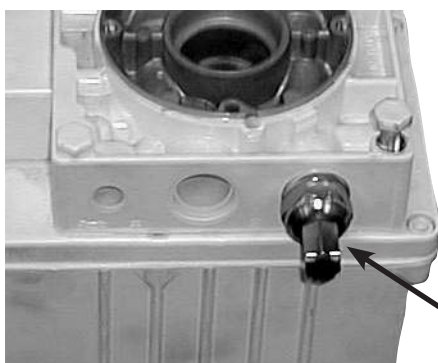

Maximum pressure is adjusted by a valve located in a corner near the base of the motor pump.

### Very Important Warning !!!

This valve must be left as set in-house by Harken otherwise the power pack may not work properly.

**Maximum Pressure Valve**

First choose the best place for the installation:

- Dry, well ventilated area
- An area as close as possible to the center of the system
- An area as close as possible to the batteries

Allow enough room around the hydraulic power pack for installation and maintenance. Be sure to leave room around the oil fill lid and oil drain plug so it is easy to fill and drain oil.

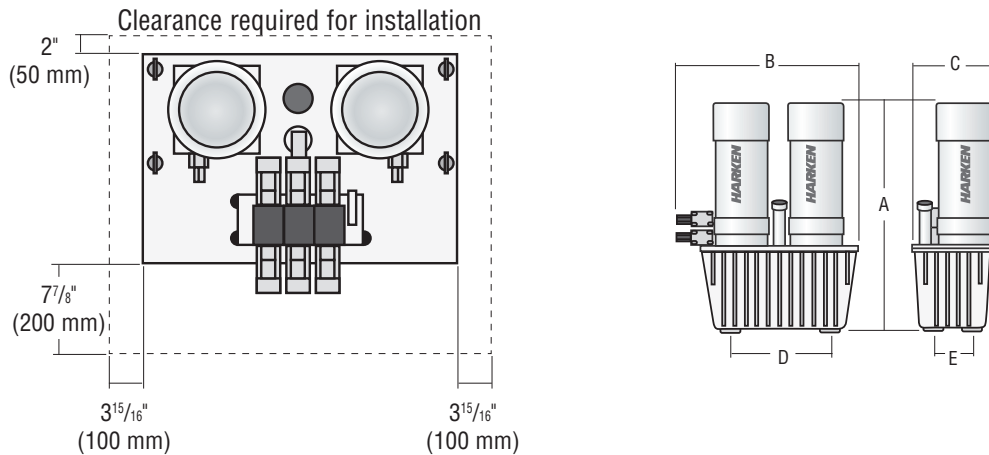

## Power Unit Dimensions

Part No.	A		B		C		D		E	
	in	mm	in	mm	in	mm	in	mm	in	mm
Hydro 4	25	635	16 <sup>17</sup> / <sub>32</sub>	420	9 <sup>7</sup> / <sub>16</sub>	240	9 <sup>13</sup> / <sub>16</sub>	250	6 <sup>1</sup> / <sub>16</sub>	170
Hydro 6	27 <sup>9</sup> / <sub>16</sub>	700	23 <sup>3</sup> / <sub>8</sub>	600	16 <sup>17</sup> / <sub>32</sub>	420	12 <sup>13</sup> / <sub>16</sub>	326	6 <sup>15</sup> / <sub>16</sub>	176
Hydro 8	29 <sup>15</sup> / <sub>16</sub>	760	31 <sup>1</sup> / <sub>2</sub>	800	18 <sup>11</sup> / <sub>16</sub>	475	15 <sup>9</sup> / <sub>16</sub>	395	10 <sup>13</sup> / <sub>16</sub>	275

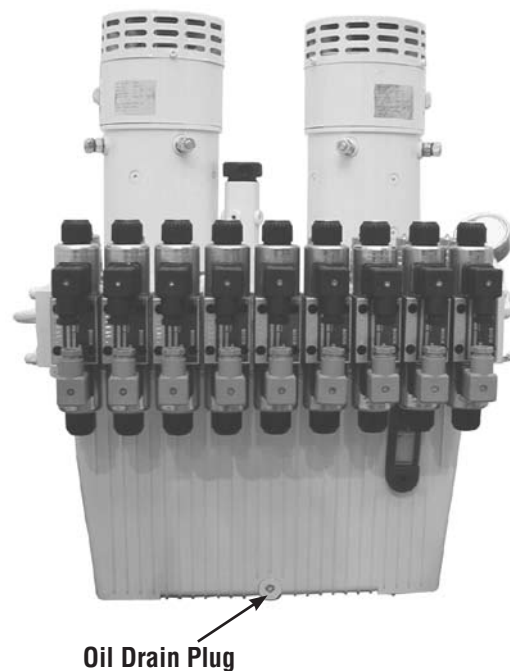
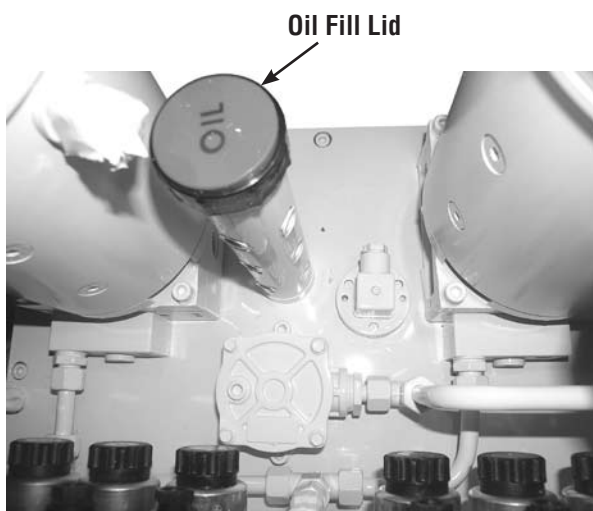

Once the best place is found for the installation, begin fastening the hydraulic unit by using 4 M10 bolts placed inside the four threaded holes on the bottom of the oil reservoir. **Important: be sure the bolts are not too long as they can pass through the reservoir.**

Place the electrical control box close to the hydraulic power pack. Make sure it is easy to access the box for maintenance and fuse checks.

Link the various functions following the instructions on page 4.

**Important: Hoses and fittings must be SAE 100 R2 hose with double metallic braid core or SAE 100 R8 tube with Kevlar® braid core.**

Hose Type	Diameter in	Max Length m (ft)	Max Working Pressure Bar (PSI)	Min Radius Bend mm (in)
SAE 100 R2	1/4	Only for hydraulic rams	400 (5800)	100 (4)
SAE 100 R2	3/8	10 (33)	330 (4800)	130 (5)
SAE 100 R2	1/2	15 (49)	275 (4000)	180 (7)
SAE 100 R2	5/8	15 (49)	250 (3600)	200 (8)
SAE 100 R2	3/4	15 (49)	215 (3100)	240 (9)
SAE 100 R8	1/4	Only for hydraulic rams	345 (5000)	35 (1.37)
SAE 100 R8	3/8	10 (33)	275 (4000)	65 (2.5)
SAE 100 R8	1/2	15 (49)	285 (4100)	75 (3)
SAE 100 R8	5/8	15 (49)	285 (4100)	205 (6)

### Very Important

***Please follow the minimum hose radius recommendations shown in the shaded column above.***

Hoses/fittings can be galvanized or stainless steel, but please remember that ***galvanized steel is not suitable for saltwater applications because it rusts easily.***

Hoses fittings must be installed using appropriate tools by qualified personnel.

There are many types of thread terminals. The most common are:

- JIC thread UNF with 37° flare. This terminal is used by Navtec or Caritec (hydraulic ram manufacturers).
- BSPP thread BSPP cylindrical with 60° flare. This terminal matches the flare of both our hydraulic power pack and hydraulic winch motors.

***We strongly recommend using the same type of flaring throughout the system for ease of purchase and for maintenance.***

Connections with high pressure hoses between the hydraulic power pack and the hydraulic function (i.e. winch, furler) must be led using the shortest and the straightest route possible, respecting the minimum bend radius using fixing collars (must be purchased separately).

Hydraulic Hose Clamps

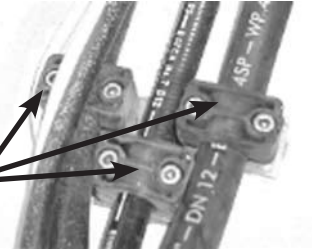

- Remember that under pressure a hose has a minimum displacement of between +2% and -4%.
- Please thoroughly support/fix hoses with hose clamps to prevent chafing and premature failure.
- Where possible avoid making 90° hose connections because they decrease the efficiency of the system.

Where possible avoid making 90° hose connections because they decrease the efficiency of the system

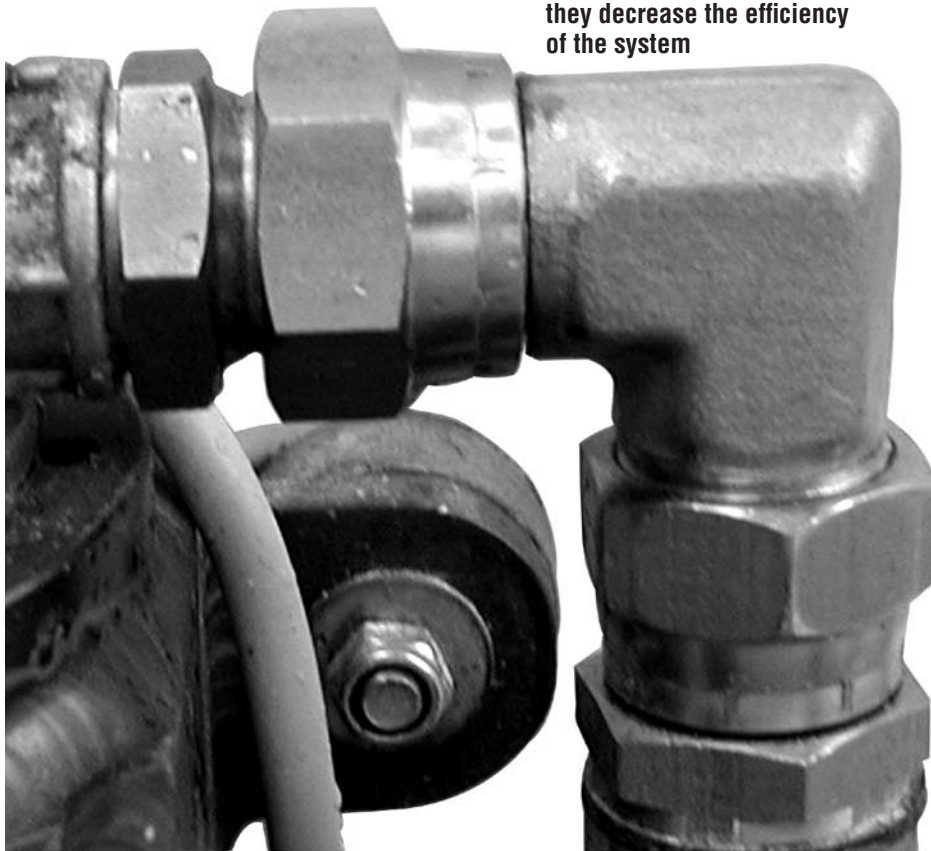

Where needed we suggest the use of 90° terminals with smooth angle.

Smooth 90° Hydraulic Hose Connection

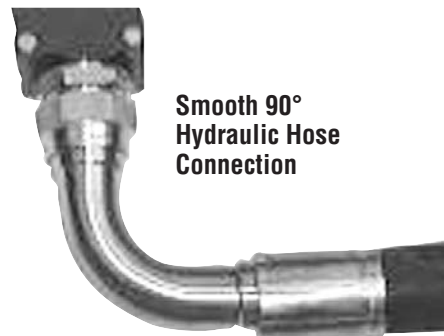

### Very Important

**Before connecting make sure insides of hoses/tubes are clean and free of debris that can damage valves.**

If the hoses/tubes are not free of debris, a flushing operation is recommended. Using an external pump, flush the line with clean, filtered hydraulic oil to remove all debris.

Remove the plugs on the hydraulic power pack valve manifold and connect the two hoses (fitted with the appropriate nipples) to each function. Lead the other ends of the hoses lead towards the hydraulic motor of the function and connect them.

BSPP and JIC connections do not need Teflon or another type of seal.



*JIC Fitting*

*BSPP Fitting*

## Case Drain Circuit

### Very Important

**Our hydraulic winches and furlers must have the case drain hose installed. We suggest using a Rilsan-type (6 x 8mm diameter) hose with 1/4 connections.**

Every hydraulic motor hose should go back to the hydraulic power pack unless specified differently by the manufacturer.

Unused ports must be kept closed.

Each case drain hose must be connected directly to the unit separate from the others.



*Just under the oil fill lid there are several ports for the case drain hoses*

Lay the electric cables to the control box from the batteries using adequate sections hereby recommended:

Wire Length Between Batteries and Control Box		Wire Size			
		Hydro 4		Hydro 6/8	
Meters	Feet	mm <sup>2</sup>	AWG	mm <sup>2</sup>	AWG
0 - 5 meters	0 - 16 ft	25	3	70	00
5 - 10 meters	16 - 33 ft	35	1	95	000
10 - 15 meters	33 - 49 ft	50	0	125	0000

Use waterproof fairlead-type IP68 to lead the cable inside the control box.

Lay the cables between the push-buttons and the box avoiding junctions; mark the cables in the box respecting the numbering during the cabling.

Carefully follow the electric schematics shown on the following pages.

It is very important to follow the numbering of the cables between valve, control box and push button.

**Example:**

Push button p1.1 must activate the coil e1.1 of the valve e1 and so on.

Lay the cables 2 x 1 mm<sup>2</sup> between the box and the valves following the electrical schematic.

Lay the supplying cables (45mm<sup>2</sup> section) between engine and box using a cable fitted with a 9mm hole terminal.

The polarity in this connection it is not important.

**Do not connect the motor until the final start-up.**

**Keep the cable terminals separated to avoid short circuits.**

Hydro 4 (Part 1)

3 positions selector clamps for switchboard selector.  
 If not linked please bridge clamps 2 - 5 and clamps 2 - 6

1 - M1 is ON  
 2 - M2 is ON  
 3 - M1 and M2 are ON

Q1 - Switch for continuous operation switchboard

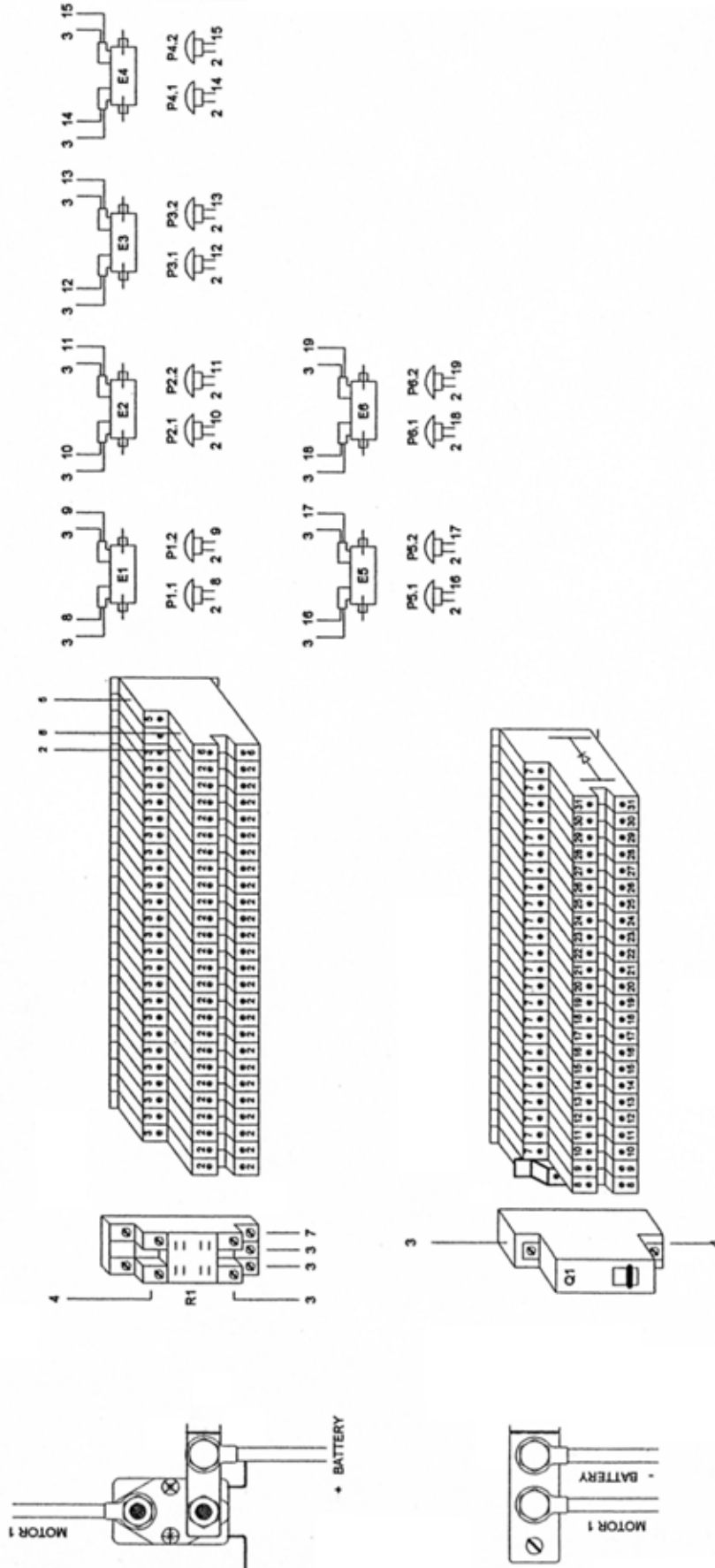

Hydro 4 (Part 2)

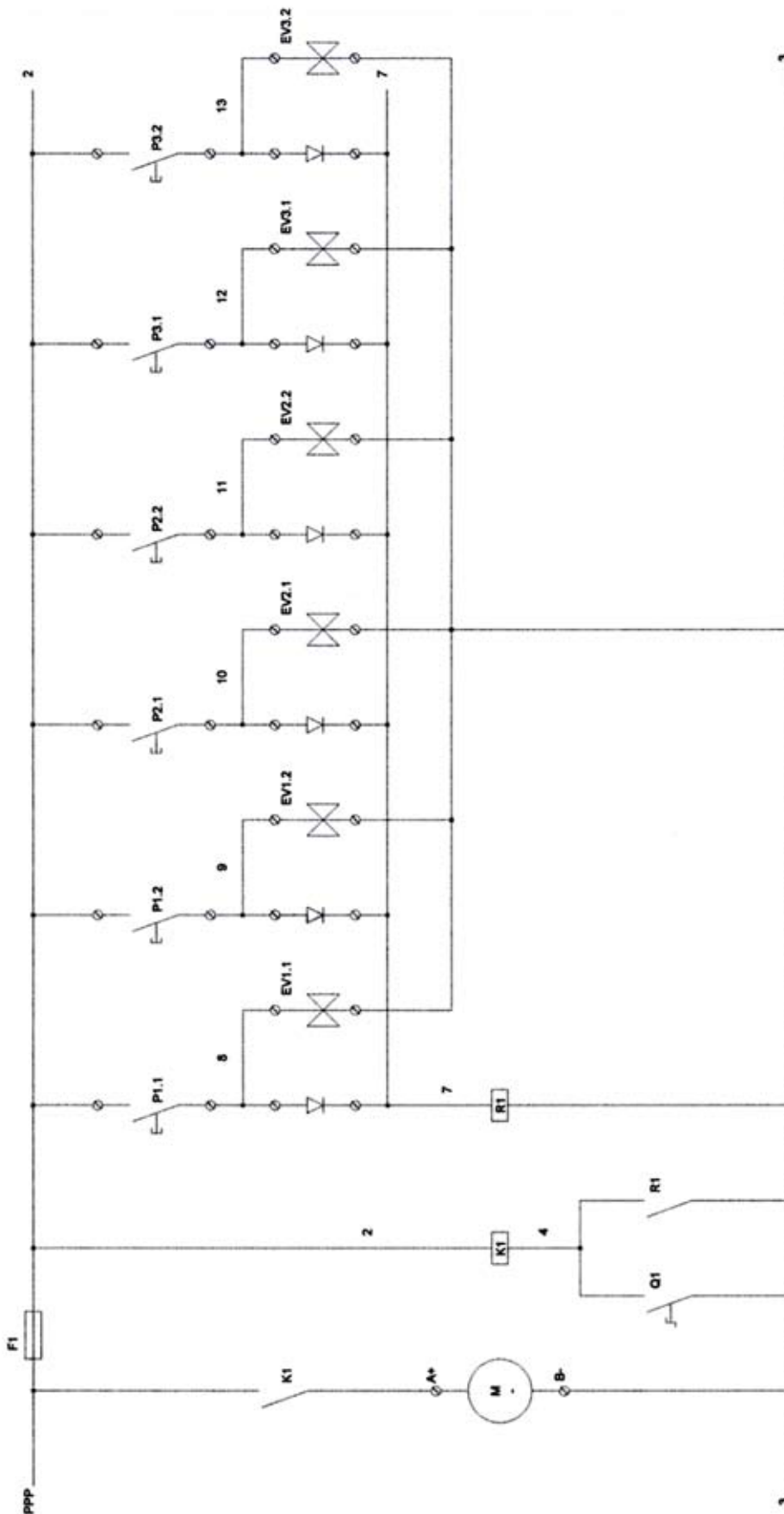

Hydro 4 (Part 3)

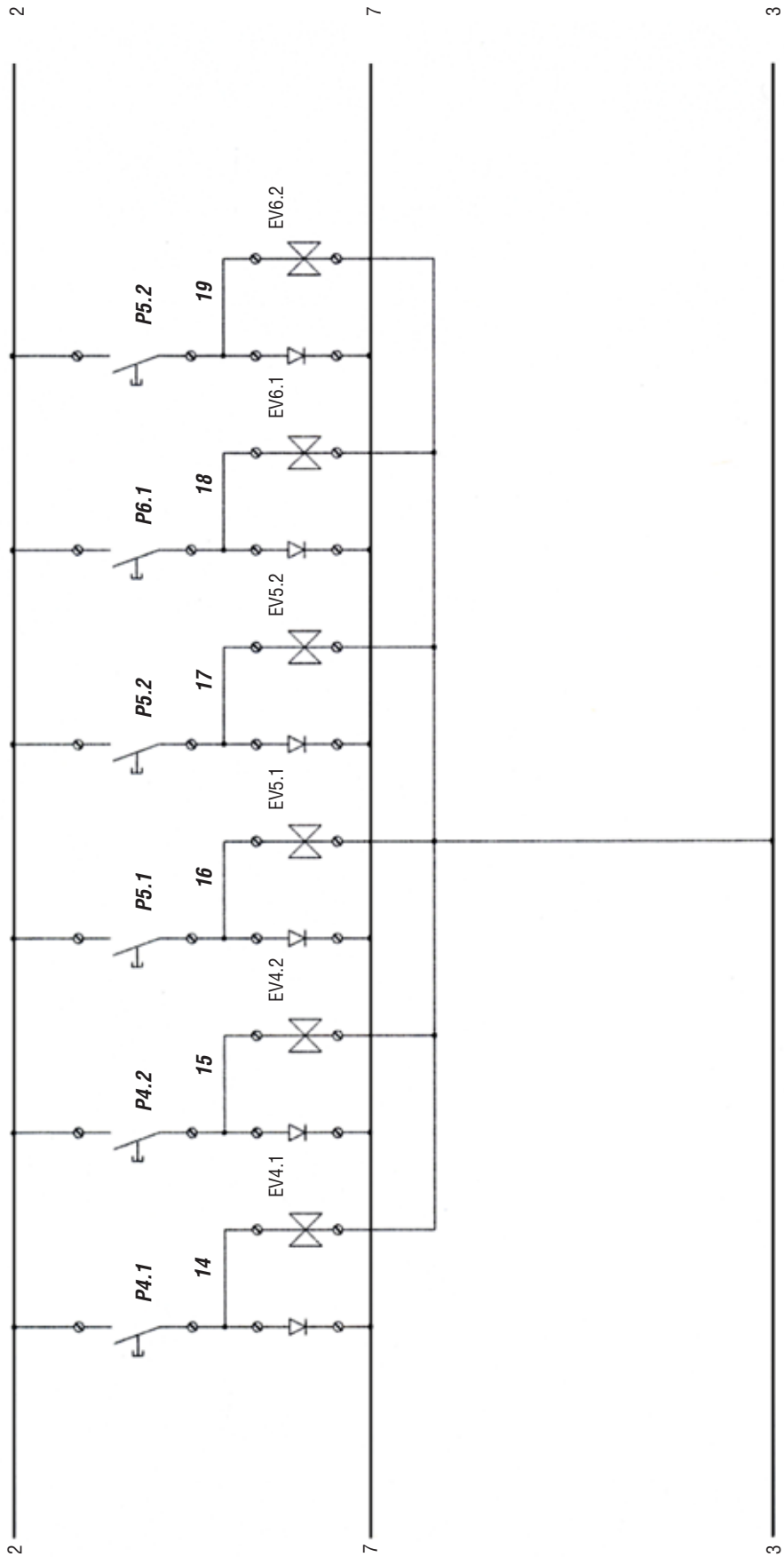



Hydro 6/8 (Part 2)

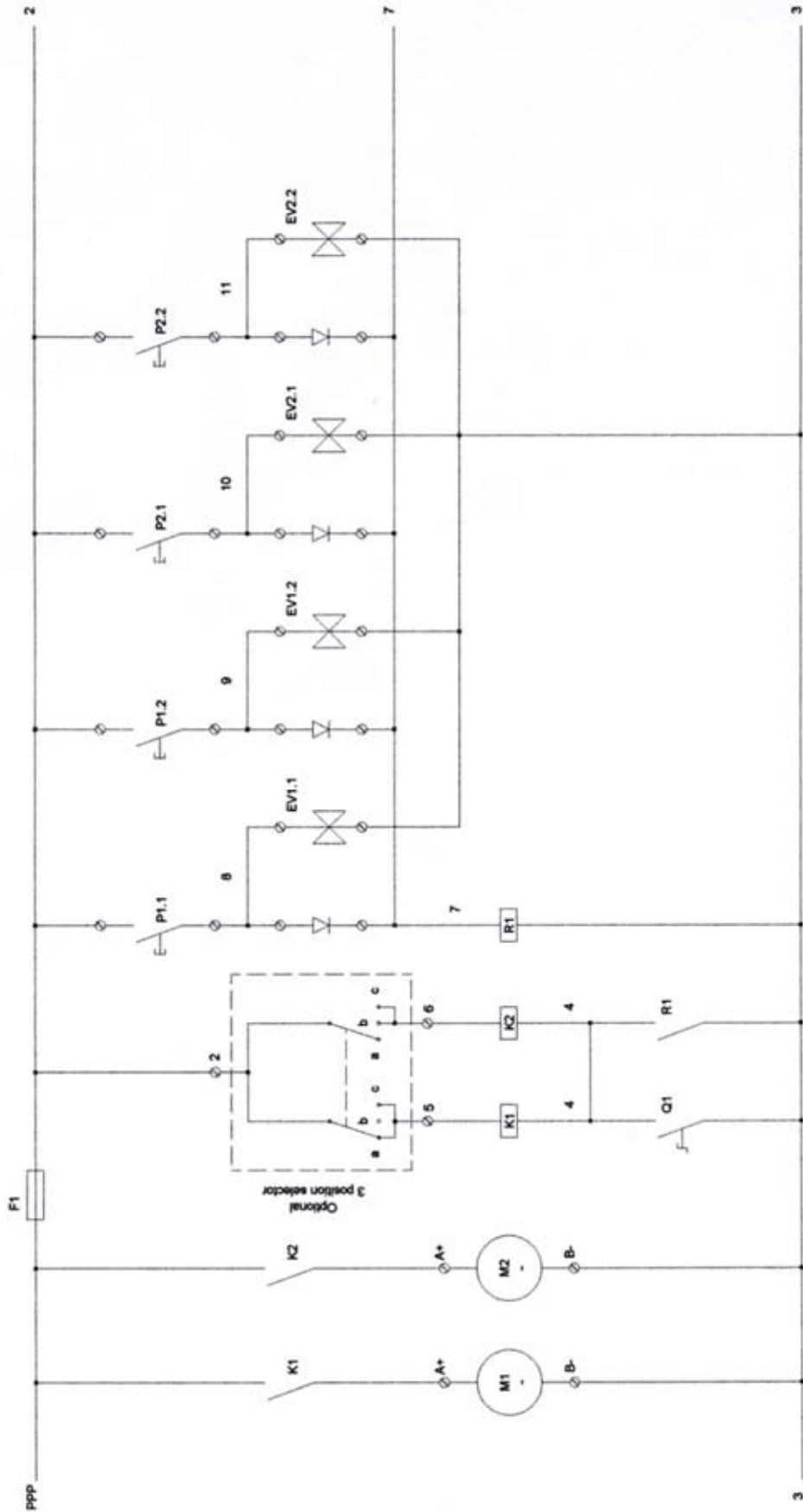

Hydro 6/8 (Part 3)

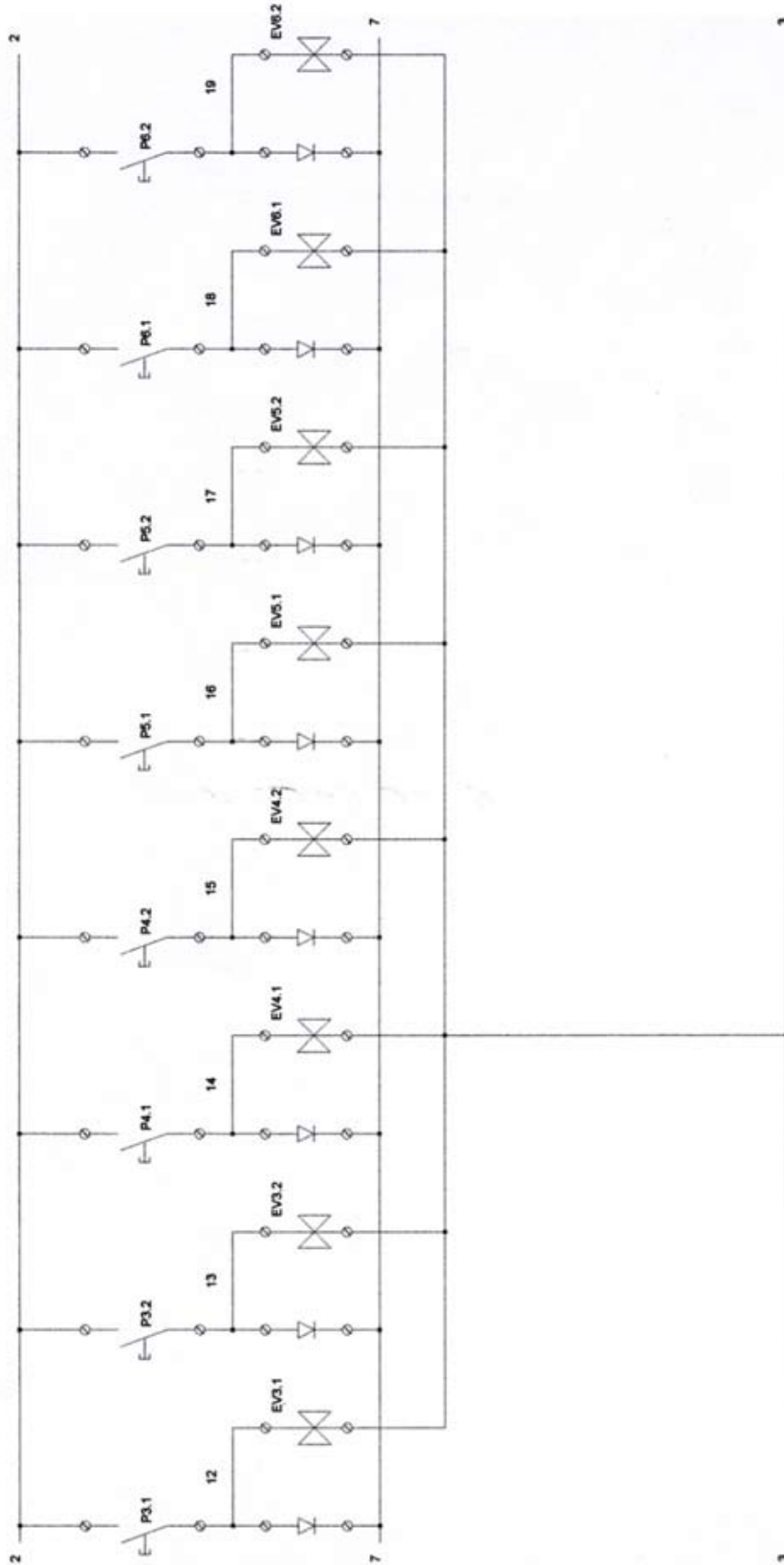

Hydro 6/8 (Part 4)

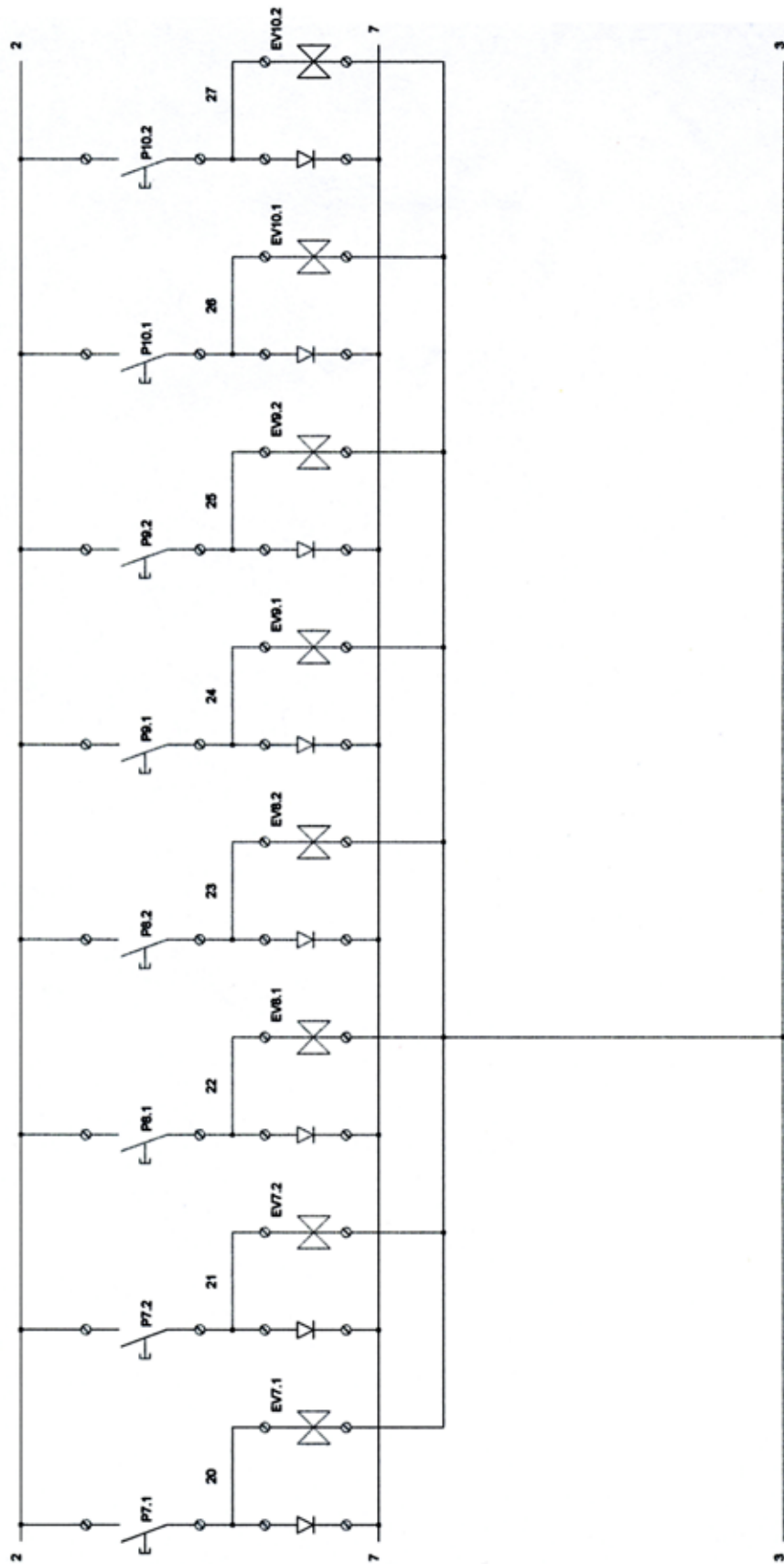

Hydro 6/8 (Part 5)

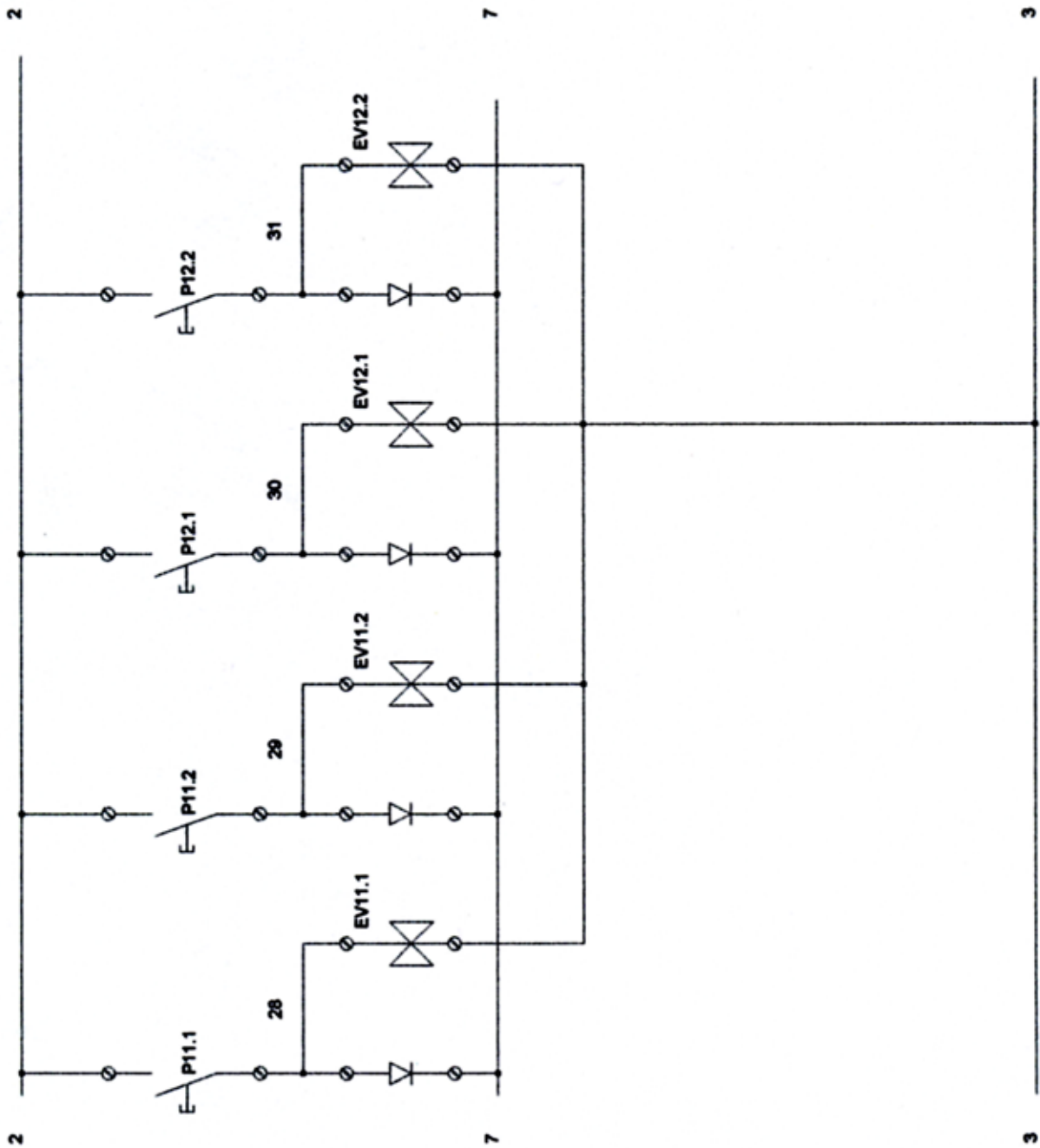

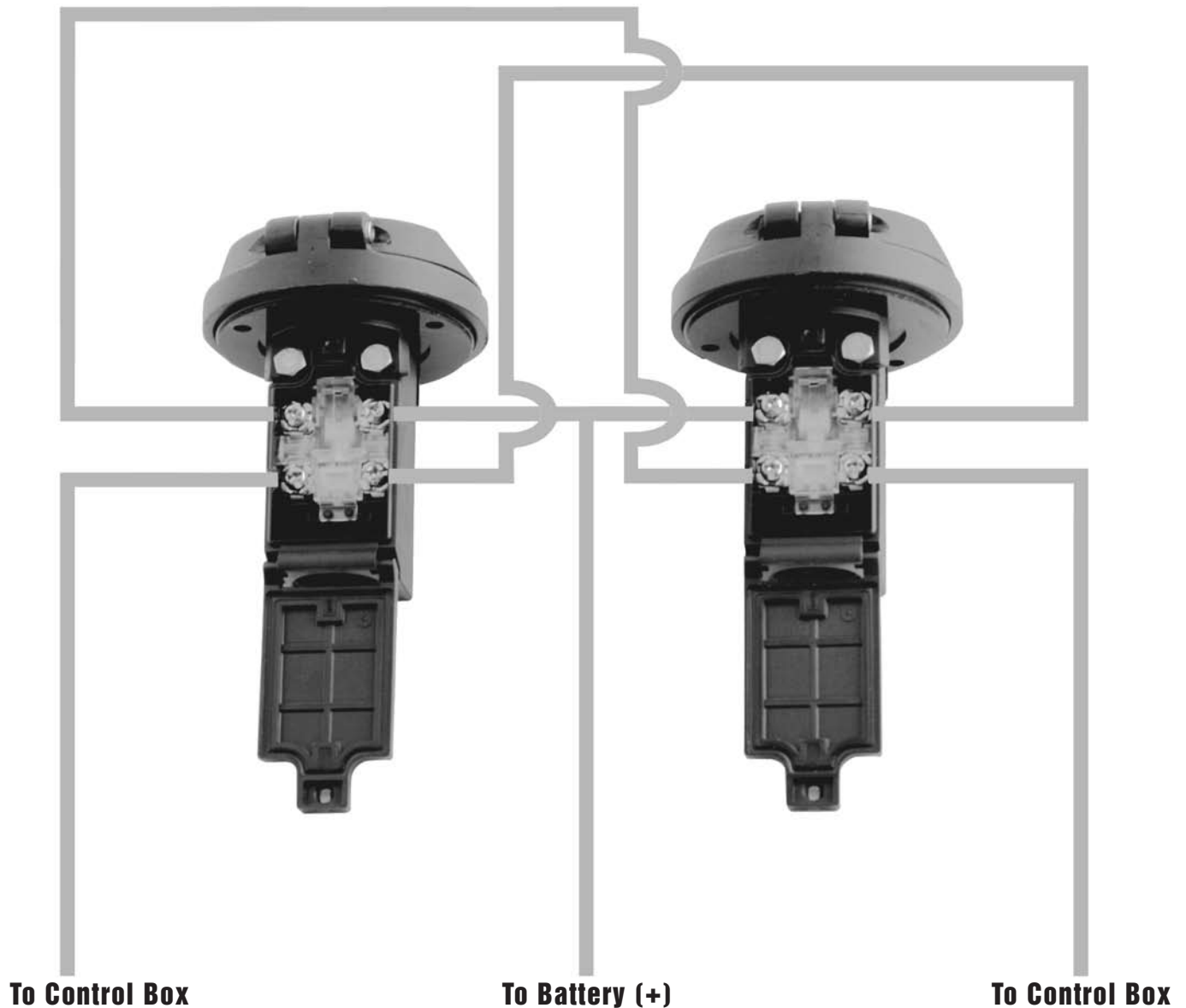
**BRS 102/P Remote Switch)****Checking Electrical Controls**

First check to make sure that the motor is disconnected and the two cables are fully isolated (the motor must always be switched off in this phase).

Then press the push-buttons one by one, while another person uses a circuit tester to make sure electric current is reaching the switch. The power must be on in the valve of the desired function when the corresponding push-button is continually depressed.

At each activation you should hear a noise coming from the remote control switch which drives the motor.

When all is working correctly the motor can be connected.

Fill the oil reservoir through the oil fill lid with the suggested type of oil (see page 2) up to the maximum level shown on the oil level on the front of the Hydraulic Power Pack. This gauge shows oil temperature as well. Keep the same quantity of oil you have used to fill in the reservoir.

### **VERY IMPORTANT WARNING**

Using the hydraulic power pack without oil can seriously damage the pump.

Oil Level And Temperature Meter



Check that all the fluid connections in the system are tight and do not leak. Activate one function at time (starting with an unloaded winch) and check for oil leaks. Because the oil is filling all of the empty hoses of the system, a decrease in oil level is normal. However, it is important that the oil level does not drop below the minimum level. Regular checks of the oil level is required during this step.

### **Air Bleeding Procedure**

Air inside the tubes will cause turbulence at the first start. To eliminate air, switch on one function after the other, staying in one gear, for about 20 seconds. In the meantime check both oil level and temperature. Doing this will push all the air inside the oil reservoir. Single- and double-effect cylinders need a special bleed procedure. Please refer to the manufacturer's instruction manual.

### **Pressure Check-up**

Open the pressure gauge on the hydraulic power pack in a counterclockwise direction and verify that the system pressure matches the manufacturer's specifications. Usually our items work at a maximum of 140 bar (2000 psi) pressure.

Please note that the pressure gauge must be kept closed (rotated clockwise) in normal conditions.

### **Maintenance**

Maintenance cycle depends on the model chosen.

#### **Weekly/Montly**

- Check oil level
- Check for oil leaks

#### **Yearly**

- Check and clean the motor brushes
- Check fluid connections
- Check hoses/tubes for wear
- Change filters
- Change oil

#### **Every Two Years**

- Change brushes

### **Very Important Warning**

**Do not use the system with low-power batteries! Low voltage will increase the amp hours consumed causing overheating of electric cables and motor.**

**A drop in electrical voltage is normal during the operation of the system.**

### Troubleshooting

#### Functions are not working.

- 1) Check to make sure the battery control switch is in ON position.
- 2) Check the fuse inside the electric box.

#### One electric push-button is not working.

- 1) Check that the push-button will turn on and off. If not, replace with a new one.
- 2) Check wires inside the push-button. If worn or cut replace.

#### The electrical motor is working but several functions do not work.

#### Other times some functions work in a stop-and-go manner.

- 1) Check the oil level. If the oil is low, fill to upper line.
- 2) Bleed the system.

#### The electric motor(s) works but the function needed does not.

- 1) Verify that the coil on the valve (for the chosen function) is powered when you push the button. If not, check valve wiring. If wiring is fine, check pressure level. If fine change the valve.

#### The system is weak: you can stop the winches by hand.

- 1) Verify that, during activation, the voltage on the battery does not go below the 24-volt level. If the voltage is under this limit, charge or purchase new batteries.
- 2) Verify that the pressure on the pressure gauge reaches 2000 psi/40 bar. If not clean or change the "max pressure" valve.
- 3) Verify that there are no oil leaks in the system.

#### Functions are turning but in slow motion.

- 1) Clean suction and return filters.

### Limited Warranty

#### **What is covered?**

Any defects in materials or workmanship

#### **How long is the warranty in effect?**

Two years from the date of final installation in yacht.

#### **Are all parts of the system covered for two years?**

Yes, all parts originally provided by Harken are covered for two years.

#### **Are there other exceptions to the warranty?**

This warranty does not cover any part of the system if it was improperly operated, improperly installed, improperly maintained, or improperly used.

#### **What is improper installation?**

Improper installation includes not following any of the procedures in the installation manual. Examples include running the Hydraulic Power Pack without oil or with a low oil level, changing the setting on the maximum pressure valve, failure to clean the inside of hoses before connecting them, and running the system using "low power" batteries.

#### **What is defined as improper maintenance?**

Improper maintenance includes not following any of the procedures in the installation manual. Examples include, but are not limited to: failure to check oil level, failure to check and periodically inspect hoses/tubes for wear, improper connection and/or oil leaks, failure to change filters and oil as recommended and failure to change brushes in the electric motor (s).

#### **What will Harken do if I have a problem?**

Harken will provide technical support by email, telephone, fax or letter to help diagnose and correct your problem. We will at our option, repair or replace any part of the Hydraulic Power Pack which fails during normal service. Replacement parts like the electric motor must come

from Harken. Hydraulic parts may be purchased, after authorization by Harken, from a qualified parts supplier. You will not be reimbursed for the cost of any part supplied by an outside vendor without prior written authorization by Harken.

#### **Will Harken pay for labor charges?**

No, labor charges are not covered by the warranty.

#### **Is Harken responsible for special, incidental or consequential damages?**

Special, incidental or consequential damages resulting from a warranty problem with a Harken Hydraulic Power Unit are not covered by this warranty.

#### **How do I get service by my Harken system?**

Most problems are installation-related and can be solved by referring to the manual. If you cannot solve the problem, call, fax or email:

#### **Harken USA**

Tel:(262) 691-3320; Fax: (262) 691-3008

Email: harken@harken.com

#### **Harken Italy**

Tel: (39) 031.3523511; Fax: (39) 031.3520031

Email: info@harken.it.

#### **What should I do if I need parts?**

After Harken determines that you need replacement or repair parts under warranty, we will ship them to you at no charge. Do not purchase repair parts without a written authorization from Harken.

#### **How does state law relate to this warranty?**

This warranty gives you specific rights but the laws of each state vary and you may also have other rights under the laws of your state.

**JIC THREAD**

Hydro Pack		Nipple		SAE 100 R8 Hose		Nipple		Utility	
Valve	Thread (in)	Thread (in)	Thread (in)	Hydraulic Power Pack Terminal	Hose Type	Utility Terminal	Thread (in)	Thread (in)	Thread (in)
ev1.1	3/8 BSPP F	3/8 BSPP M	9/16 JIC M	Swiveling female 9/16 JIC - R8 3/8	SAE 100 R8 3/8	Swiveling female 9/16 JIC - R8 3/8	9/16 JIC M	3/8 BSPP M	3/8 BSPP F
ev1.2	3/8 BSPP F	3/8 BSPP M	9/16 JIC M	Swiveling female 9/16 JIC - R8 3/8	SAE 100 R8 3/8	Swiveling female 9/16 JIC - R8 3/8	9/16 JIC M	3/8 BSPP M	3/8 BSPP F
ev2.1	3/8 BSPP F	3/8 BSPP M	1/2 JIC M	Swiveling female 3/4 JIC - R8 1/2	SAE 100 R8 1/2	Swiveling female 3/4 JIC - R8 1/2	1/2 JIC M	3/8 BSPP M	3/8 BSPP F
ev2.2	3/8 BSPP F	3/8 BSPP M	1/2 JIC M	Swiveling female 3/4 JIC - R8 1/2	SAE 100 R8 1/2	Swiveling female 3/4 JIC - R8 1/2	1/2 JIC M	3/8 BSPP M	3/8 BSPP F

Up to 10m

Up to 15m

**THREAD BSPP**

Hydro Pack		Nipple		SAE 100 R2 Hose		Nipple		Utility	
Valve	Thread (in)	Thread (in)	Thread (in)	Hydraulic Power Pack Terminal	Hose Type	Utility Terminal	Thread (in)	Thread (in)	Thread (in)
ev3.1	3/8 BSPP F	3/8 BSPP M	3/8 BSPP M	Swiveling female 3/8 BSPP - R2 3/8	SAE 100 R2 3/8	Swiveling female 3/8 BSPP - R2 3/8	3/8 BSPP M	3/8 BSPP M	3/8 BSPP F
ev3.2	3/8 BSPP F	3/8 BSPP M	3/8 BSPP M	Swiveling female 3/8 BSPP - R2 3/8	SAE 100 R2 3/8	Swiveling female 3/8 BSPP - R2 3/8	3/8 BSPP M	3/8 BSPP M	3/8 BSPP F
ev4.1	3/8 BSPP F	3/8 BSPP M	1/2 BSPP M	Swiveling female 1/2 BSPP - R2 1/2	SAE 100 R2 1/2	Swiveling female 1/2 BSPP - R2 1/2	1/2 BSPP M	3/8 BSPP M	3/8 BSPP F
ev4.2	3/8 BSPP F	3/8 BSPP M	1/2 BSPP M	Swiveling female 1/2 BSPP - R2 1/2	SAE 100 R2 1/2	Swiveling female 1/2 BSPP - R2 1/2	1/2 BSPP M	3/8 BSPP M	3/8 BSPP F
ev5.1	3/8 BSPP F	3/8 BSPP M	3/4 BSPP M	Swiveling female 3/4 BSPP - R2 3/4	SAE 100 R2 3/4	Swiveling female 3/4 BSPP - R2 3/4	3/4 BSPP M	3/8 BSPP M	3/8 BSPP F
ev5.2	3/8 BSPP F	3/8 BSPP M	3/4 BSPP M	Swiveling female 3/4 BSPP - R2 3/4	SAE 100 R2 3/4	Swiveling female 3/4 BSPP - R2 3/4	3/4 BSPP M	3/8 BSPP M	3/8 BSPP F

Up to 10m

Up to 15m

Over 15m

**Record Your Connections for Future Reference**

Hydro Pack		Nipple		SAE 100 R2 Hose		Nipple		Utility	
Valve	Thread (in)	Thread (in)	Thread (in)	Hydraulic Power Pack Terminal	Hose Type	Utility Terminal	Thread (in)	Thread (in)	Thread (in)
ev1.1	3/8 BSPP F							1/2 BSPP M	1/2 BSPP F
ev1.2	3/8 BSPP F	3/8 BSPP M						1/2 BSPP M	1/2 BSPP F
ev2.1	3/8 BSPP F	3/8 BSPP M							
ev2.2	3/8 BSPP F	3/8 BSPP M							
ev3.1	3/8 BSPP F	3/8 BSPP M							
ev3.2	3/8 BSPP F	3/8 BSPP M							
ev4.1	3/8 BSPP F	3/8 BSPP M							
ev4.2	3/8 BSPP F	3/8 BSPP M							
ev5.1	3/8 BSPP F	3/8 BSPP M							
ev5.2	3/8 BSPP F	3/8 BSPP M							
ev6.1	3/8 BSPP F	3/8 BSPP M							
ev6.2	3/8 BSPP F	3/8 BSPP M							

Primary winch on the right

### JIC THREAD

Hydro Pack		Nipple		SAE 100 R8 Hose		Nipple		Utility	
Valve	Thread (in)	Thread (in)	Thread (in)	Hydraulic Power Pack Terminal	Hose Type	Utility Terminal	Thread (in)	Thread (in)	Thread (in)
ev1.1	3/8 BSPP F	3/8 BSPP M	9/16 JIC M	Swiveling female 9/16 JIC - R8 3/8	SAE 100 R8 3/8	Swiveling female 9/16 JIC - R8 3/8	9/16 JIC M	3/8 BSPP M	3/8 BSPP F
ev1.2	3/8 BSPP F	3/8 BSPP M	9/16 JIC M	Swiveling female 9/16 JIC - R8 3/8	SAE 100 R8 3/8	Swiveling female 9/16 JIC - R8 3/8	9/16 JIC M	3/8 BSPP M	3/8 BSPP F
ev2.1	3/8 BSPP F	3/8 BSPP M	1/2 JIC M	Swiveling female 3/4 JIC - R8 1/2	SAE 100 R8 1/2	Swiveling female 3/4 JIC - R8 1/2	1/2 JIC M	3/8 BSPP M	3/8 BSPP F
ev2.2	3/8 BSPP F	3/8 BSPP M	1/2 JIC M	Swiveling female 3/4 JIC - R8 1/2	SAE 100 R8 1/2	Swiveling female 3/4 JIC - R8 1/2	1/2 JIC M	3/8 BSPP M	3/8 BSPP F

Up to 10m

Up to 15m

### BSPP THREAD

Hydro Pack		Nipple		SAE 100 R2 Hose		Nipple		Utility	
Valve	Thread (in)	Thread (in)	Thread (in)	Hydraulic Power Pack Terminal	Hose Type	Utility Terminal	Thread (in)	Thread (in)	Thread (in)
ev3.1	3/8 BSPP F	3/8 BSPP M	3/8 BSPP M	Swiveling female 3/8 BSPP - R2 3/8	SAE 100 R2 3/8	Swiveling female 3/8 BSPP - R2 3/8	3/8 BSPP M	3/8 BSPP M	3/8 BSPP F
ev3.2	3/8 BSPP F	3/8 BSPP M	3/8 BSPP M	Swiveling female 3/8 BSPP - R2 3/8	SAE 100 R2 3/8	Swiveling female 3/8 BSPP - R2 3/8	3/8 BSPP M	3/8 BSPP M	3/8 BSPP F
ev4.1	3/8 BSPP F	3/8 BSPP M	1/2 BSPP M	Swiveling female 1/2 BSPP - R2 1/2	SAE 100 R2 1/2	Swiveling female 1/2 BSPP - R2 1/2	1/2 BSPP M	3/8 BSPP M	3/8 BSPP F
ev4.2	3/8 BSPP F	3/8 BSPP M	1/2 BSPP M	Swiveling female 1/2 BSPP - R2 1/2	SAE 100 R2 1/2	Swiveling female 1/2 BSPP - R2 1/2	1/2 BSPP M	3/8 BSPP M	3/8 BSPP F
ev5.1	3/8 BSPP F	3/8 BSPP M	3/4 BSPP M	Swiveling female 3/4 BSPP - R2 3/4	SAE 100 R2 3/4	Swiveling female 3/4 BSPP - R2 3/4	3/4 BSPP M	3/8 BSPP M	3/8 BSPP F
ev5.2	3/8 BSPP F	3/8 BSPP M	3/4 BSPP M	Swiveling female 3/4 BSPP - R2 3/4	SAE 100 R2 3/4	Swiveling female 3/4 BSPP - R2 3/4	3/4 BSPP M	3/8 BSPP M	3/8 BSPP F

Up to 10m

Up to 15m

Over 15m

### Record Your Connections for Future Reference

Hydro Pack		Nipple		SAE 100 R2 Hose		Nipple		Utility	
Valve	Thread (in)	Thread (in)	Thread (in)	Hydraulic Power Pack Terminal	Hose Type	Utility Terminal	Thread (in)	Thread (in)	Thread (in)
ev1.1	3/8 BSPP F							1/2 BSPP M	1/2 BSPP F
ev1.2	3/8 BSPP F	3/8 BSPP M						1/2 BSPP M	1/2 BSPP F
ev2.1	3/8 BSPP F	3/8 BSPP M							
ev2.2	3/8 BSPP F	3/8 BSPP M							
ev3.1	3/8 BSPP F	3/8 BSPP M							
ev3.2	3/8 BSPP F	3/8 BSPP M							
ev4.1	3/8 BSPP F	3/8 BSPP M							
ev4.2	3/8 BSPP F	3/8 BSPP M							
ev5.1	3/8 BSPP F	3/8 BSPP M							
ev5.2	3/8 BSPP F	3/8 BSPP M							
ev6.1	3/8 BSPP F	3/8 BSPP M							
ev6.2	3/8 BSPP F	3/8 BSPP M							

Primary winch on the right

**JIC THREAD**

Hydro Pack		Nipple		SAE 100 R8 Hose		Nipple		Utility	
Valve	Thread (in)	Thread (in)	Thread (in)	Hydraulic Power Pack Terminal	Hose Type	Utility Terminal	Thread (in)	Thread (in)	Thread (in)
ev1.1	3/8 BSPP F						3/8 BSPP M	3/8 BSPP M	3/8 BSPP F
ev1.2	3/8 BSPP F						3/8 BSPP M	3/8 BSPP M	3/8 BSPP F
ev2.1	3/8 BSPP F						3/8 BSPP M	3/8 BSPP M	3/8 BSPP F
ev2.2	3/8 BSPP F						3/8 BSPP M	3/8 BSPP M	3/8 BSPP F
ev3.1	3/8 BSPP F						3/8 BSPP M	3/8 BSPP M	3/8 BSPP F
ev3.2	3/8 BSPP F						3/8 BSPP M	3/8 BSPP M	3/8 BSPP F
ev4.1	3/8 BSPP F						3/8 BSPP M	3/8 BSPP M	3/8 BSPP F
ev4.2	3/8 BSPP F						3/8 BSPP M	3/8 BSPP M	3/8 BSPP F
ev5.1	3/8 BSPP F						3/8 BSPP M	3/8 BSPP M	3/8 BSPP F
ev5.2	3/8 BSPP F						3/8 BSPP M	3/8 BSPP M	3/8 BSPP F
ev6.1	3/8 BSPP F						3/8 BSPP M	3/8 BSPP M	3/8 BSPP F
ev6.2	3/8 BSPP F						3/8 BSPP M	3/8 BSPP M	3/8 BSPP F

# **HARKEN®**

## **Corporate Headquarters**

1251 East Wisconsin Avenue, Pewaukee, Wisconsin 53072 USA  
Telephone: (262) 691-3320 • Fax: (262) 691-3008 • Cable: Harken Pewaukee  
Web: [www.harken.com](http://www.harken.com) • Online Catalog: [www.harkenstore.com](http://www.harkenstore.com)  
Email: [harken@harken.com](mailto:harken@harken.com)

## **Harken France**

ZA. Port des Minimes, BP 3064, 17032 - La Rochelle Cedex 1, France  
Telephone: (33) 05.46.44.51.20 • Fax: (33) 05.46.44.25.70  
Web: [www.harken.fr](http://www.harken.fr)  
Email: [harken@harken.fr](mailto:harken@harken.fr)

## **Harken Italy S.P.A.**

Via Della Cerca, 12/14, 22070 Lurago Marinone, Como, Italy  
Telephone: (39) 031.3523511 • Fax: (39) 031.3520031  
Web: [www.harken.it](http://www.harken.it)  
Email: [info@harken.it](mailto:info@harken.it)

## **Harken UK**

Bearing House, Ampress Lane  
Lymington, Hampshire SO41 8LW, England  
Telephone: (44) 01590-689122 • Fax: (44) 01590-610274  
Web: [www.harken.co.uk](http://www.harken.co.uk)  
Email: [enquiries@harken.co.uk](mailto:enquiries@harken.co.uk)

## **Harken Sweden**

Mjölkekilsgatan 6, Box 64  
S-440 30 Marstrand, Sweden  
Telephone: (46) 303-618 75 • Fax: (46) 303-618 76  
Web: [www.harken.se](http://www.harken.se)  
Email: [harken@harken.se](mailto:harken@harken.se)

Please visit: <http://www.harken.com/dealers/dealers.php> for an up-to-date list of Harken dealers and distributors



0 97653 17568 1

4/6/8/ Hydraulic Power Units/1-06